

# PRODUCT INFORMATION PACKET

Model No: 5KH37PN39

Catalog No: H112

General Purpose Motor, 0.17 HP, 1 Ph, 60 Hz, 115 V, 1200 RPM, 48 Frame, DP



Regal and Marathon are trademarks of Regal Rexnord Corporation or one of its affiliated companies.

©2023 Regal Rexnord Corporation, All Rights Reserved. MC017097E



### Nameplate Specifications

Output HP	0.17 Hp	Output KW	0.13 kW
Frequency	60 Hz	Voltage	115 V
Current	4 A	Speed	1140 rpm
Service Factor	1.35	Phase	1
Efficiency	50.5 %	Power Factor	0
Duty	Continuous	Insulation Class	B
KVA Code	P	Frame	48
Enclosure	Drip Proof	Thermal Protection	No Protection
Ambient Temperature	40 °C	Drive End Bearing Size	6203
Opp Drive End Bearing Size	6203	UL	Recognized
CSA	Yes	CE	N
Number of Speeds	1		

### Technical Specifications

Electrical Type	Split Phase	Starting Method	SM
Poles	6	Rotation	Counterclockwise/Clockwise
Mounting	Resilient Base	Motor Orientation	ANY
Drive End Bearing	BALL	Opp Drive End Bearing	Ball
Frame Material	Rolled Steel	Overall Length	10.4 in
Frame Length	6.62 in	Shaft Diameter	0.500 in
Shaft Extension	1.5 in		
Connection Drawing	121A850	Outline Drawing	52A101440P5

This is an uncontrolled document once printed or downloaded and is subject to change without notice. Date Created:01/30/2023

SHEET 1  
REV 8  
52A101440  
SIZE DRAWING NO. A

THIRD ANGLE PROJECTION

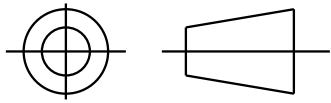

REVISIONS

REV.	DESCRIPTION	DATE	APPROVED
7	REDRAWN NO CHANGE TI96-22390	07/10/96	MDP
8	CHG TO RBC FORMAT PER IS 05-1777	15/12/05	GOVARDAN

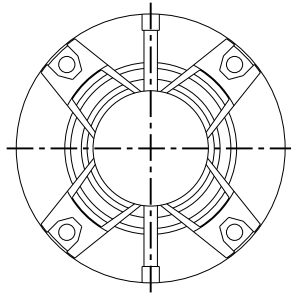

VIEW SHOWING PE VENTILATION OPENINGS

.05 X 1.16 LG. FULL FLAT

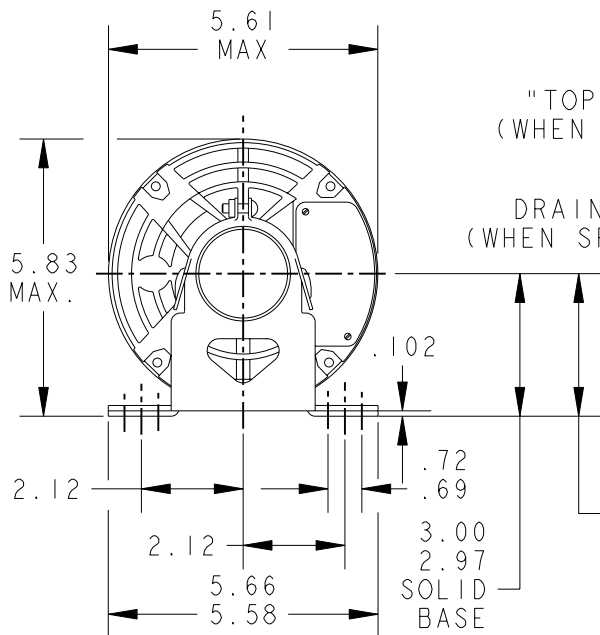

"TOP" STICKER (WHEN SPECIFIED)

DRAIN HOLES (WHEN SPECIFIED)

.500-14 CONDUIT THREAD

3.00  
2.94  
RESIL BASE

3.00  
2.97  
SOLID BASE

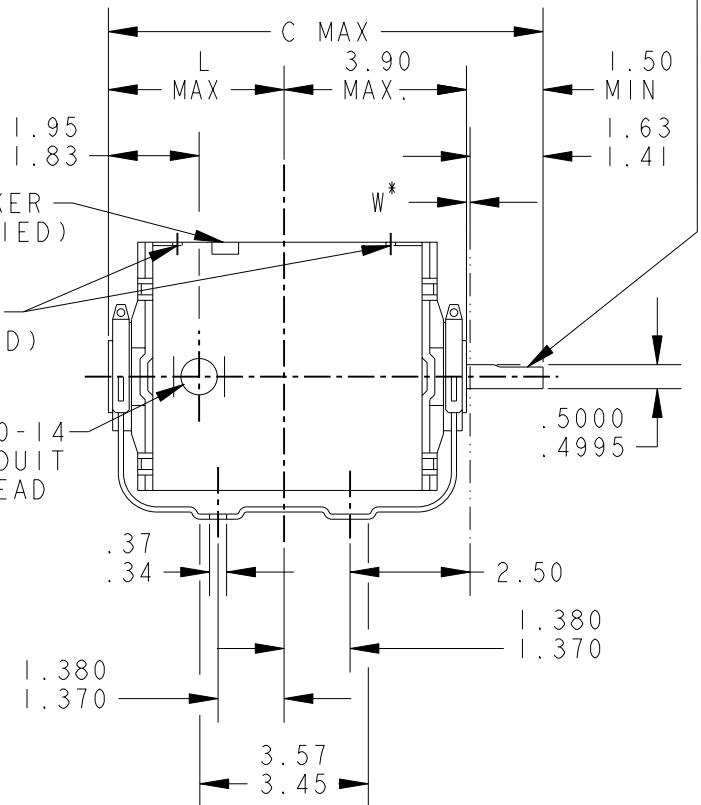

\*W IS A CLEARANCE DUE TO VARIATION IN PARTS & ASSEMBLY.

3	KH	33	48	9.19	3.84	6	KH	38	48	11.00	5.65
2	KH	32	48	8.94	3.59	5	KH	37	48	10.40	5.05
1	KH	35	48	9.57	4.22	4	KH	36	48	10.00	4.65
PT	TYPE	GE SIZE	NEMA FR	C	L	PT	TYPE	GE SIZE	NEMA FR	C	L

SIGNATURES	DATE
MODEL GLB	11/14/74
DETAIL .	.
CHECKED .	.
ENGRG .	.
MFG .	.
QUALITY .	.
ISSUED MDP	07/10/96
SOLID MODEL: 52A101440	



REGAL-BELOIT CORPORATION

TITLE  
**OUTLINE**  
**FORM G - GENERAL PURPOSE MOTOR - DRIP PROOF - SOLID OR RESIL BASE - BALL OR SLEEVE BEARING**

SIZE DRAWING	52A101440	REV 8
A	SCALE: 1.000	REF. No: .
SHEET 1 of 1		

FOR ADDITIONAL INFO REFER TO:  
APPLIED PRACTICES .  
DIMENSIONS ARE IN INCHES ✓  
MATERIAL .

